

# H3EA Element SST CE UK

Height: 22.3" (56.6cm) Width: 8.2" (20.8cm) Depth: 20.4" (51.8cm)



- LED display provides simple temperature adjustment
- Thinsulate® tank insulation provides increased energy efficiency
- Digital thermostat provides consistent and accurate temperatures of 15.6-96C (Deg) (60-205F MAX)
- Contemporary, low-profile design for front-of-house and self-service settings
- Matching Blue LED dispense button
- Programmable "Energy Saver Mode" reduces operating costs during idle periods
- 196mm (7.75in) cup clearance accommodates a range of serving options for custom-crafted, hand pour coffees and teas

Agency:



CAFFEINE LIMITED  
3 LITTLE MUNDELLS, WELWYN GARDEN CITY  
HERTFORDSHIRE, UNITED KINGDOM, AL7 1EW  
T. 01707 278 400 [caffeineonline.co.uk](http://caffeineonline.co.uk)



## Specifications

**Product #:** 45300.0000

**Water Access:** Plumbed

**Finish:** Stainless

**Temp. Setting:** 205°F (96.111°C)

**Dispense:** Portion Control

**Dispense:** Push Button

## Additional Features

## Electrical & Capacity

| Volts*  | Amps      | Watts     | Cord Attached | Plug Type | 8oz cups/hr<br>236ml cups/hr | Input H <sub>2</sub> O Temp. | Phase | # Wires plus Ground | Hertz |
|---------|-----------|-----------|---------------|-----------|------------------------------|------------------------------|-------|---------------------|-------|
| 220-240 | 11.5-12.5 | 2500-3000 | Yes           | UK 13A    | -                            | 60°F (15.5°C)                | 1     | 2                   | 50-60 |

\*When a BUNN is machine rated 120/208-240V, 120/208V or 120/240V, the higher voltage is the supply voltage needed to power the machine. The 120V is there to supply power to some components rated 120V in the machine, but it is not the supply voltage and would not power the machine if the machine is marked with the before mentioned ratings.

## Plumbing Requirements

| PSI   | kPa     | Fitting Supplied | Water Flow Required (GPM) |
|-------|---------|------------------|---------------------------|
| 20-90 | 138-621 | 3/4" BSPP        | -                         |

## CAD Drawings

| 2D | Revit | KLC |
|----|-------|-----|
| ●  |       |     |

**WARNING:**



BUNN® reserves the right to change specifications and product design without notice. Such revisions do not entitle the buyer to corresponding changes, improvements, additions or replacements for previously purchased equipment. For most current specifications and other info visit [bunn.com](http://bunn.com).

Last Updated:  
02/27/2023

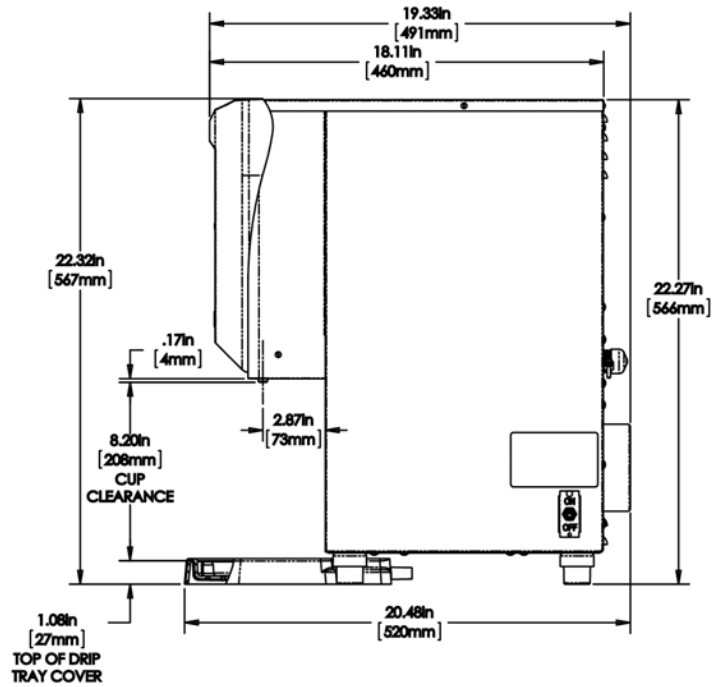
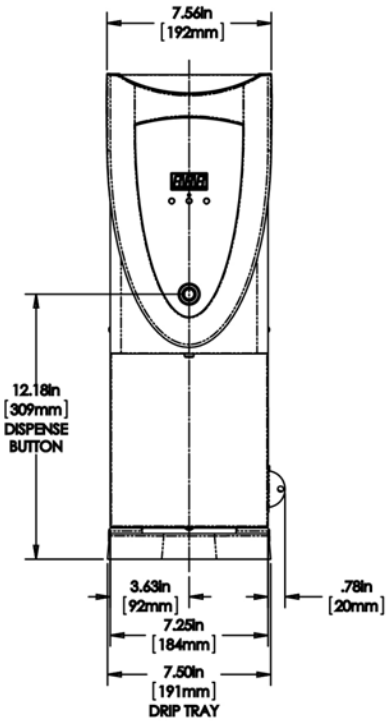
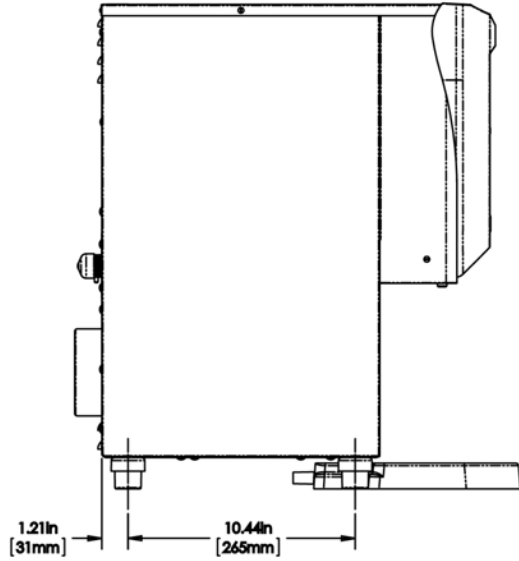
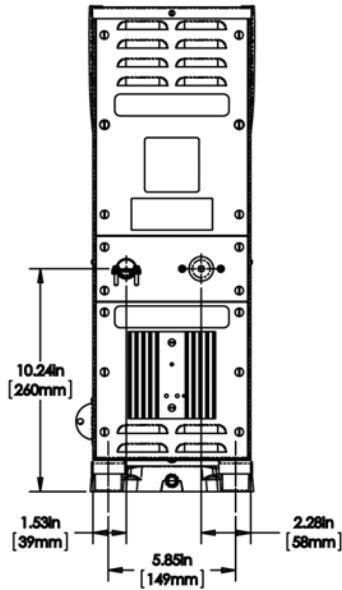

|         | Unit     |         |          | Shipping |          |          |            |                       |
|---------|----------|---------|----------|----------|----------|----------|------------|-----------------------|
|         | Height   | Width   | Depth    | Height   | Width    | Depth    | Weight     | Volume                |
| English | 22.3 in. | 8.2 in. | 20.4 in. | 32.3 in. | 10.8 in. | 21.9 in. | 34.000 lbs | 4.423 ft <sup>3</sup> |
| Metric  | 56.6 cm  | 20.8 cm | 51.8 cm  | 82.1 cm  | 27.5 cm  | 55.6 cm  | 15.422 kgs | 0.125 m <sup>3</sup>  |



BUNN® reserves the right to change specifications and product design without notice. Such revisions do not entitle the buyer to corresponding changes, improvements, additions or replacements for previously purchased equipment. For most current specifications and other info visit [bunn.com](http://bunn.com).

Last Updated:  
02/27/2023

# Related Products & Accessories:H3EA Element SST CE UK(45300.0000)



WATER FILTER,  
EQHP-10L

Product #: 39000.0001

TRAY, DRIP H3E  
ELEMENT

Product #: 48885.0001



SYSTEM, WQ-55(2)5L

Product #: 56000.0001



SYSTEM, WEQ-10(1.5)5L

Product #: 56000.0024



CARTRIDGE, WQ-55(2)5L

Product #: 56000.0101



CARTRIDGE, WEQ-10  
(1.5)5L

Product #: 56000.0121



BUNN® reserves the right to change specifications and product design without notice. Such revisions do not entitle the buyer to corresponding changes, improvements, additions or replacements for previously purchased equipment. For most current specifications and other info visit [bunn.com](http://bunn.com).

Last Updated:  
02/27/2023

# Serving & Holding Options: H3EA Element SST CE UK(45300.0000)

\*Serving and Holding selections are currently unavailable. Please contact your sales representative to find out more information.\*



BUNN® reserves the right to change specifications and product design without notice. Such revisions do not entitle the buyer to corresponding changes, improvements, additions or replacements for previously purchased equipment. For most current specifications and other info visit [bunn.com](http://bunn.com).

Last Updated:  
02/27/2023